

**BEE 233 Circuits**  
**Fall 2015 lab rubric**  
*Tuesday section AA only*

**Instructor** Nicole Hamilton  
<http://faculty.washington.edu/kd1uj/nicole@nicolehamilton.com>  
H: 425-702-8184  
C: 425-765-9574  
Office hours: Mondays and Wednesdays, 3:30 pm to 5:30 pm  
Beardslee 276 conference room

**Lab hours** Tuesdays, 3:30 pm to 5:30 pm  
Discovery 264

### Organization

This rubric only applies to my Tuesday section. Dr. Aintablian has posted some different instructions for his section.

BEE 233 introduces the concepts and techniques needed to analyze the transient and steady-state behavior of AC circuits. This laboratory is organized as a series of four (maybe 5) assignments due at roughly two-week intervals that are intended to develop your skills in the laboratory and allow you to discover what happens when you try to build an example of a circuit you've learned about in the lectures and the degree to which real circuits behave the way the way the math predicts.

These are the labs you'll be doing. I'll post the details of each about a week before you begin it.

- Lab 1: Introduction to using our lab instruments
- Lab 2: Step response of RC circuits
- Lab 3: Operational amplifiers
- Lab 4: Integrators, differentiators and simple filters
- Possible lab 5: TBD

### Come prepared

All but the first lab require a significant amount of prelab work analyzing the equations describing the circuits you'll be measuring experimentally or to chose component values.

You'll get a kit of parts Here's what's in your parts kit. All the resistors are 1/4 W, 5% (gold band).

**Qty Description**

- 2 51  $\Omega$  resistor  
green/brown/black
- 5 1 K $\Omega$  resistor  
brown/black/red
- 4 5.1 K $\Omega$  resistor  
green/brown/red
- 6 10 K $\Omega$  resistor  
brown/black/orange
- 3 20 K $\Omega$  resistor  
red/black/orange
- 2 27 K $\Omega$  resistor  
red/violet/orange

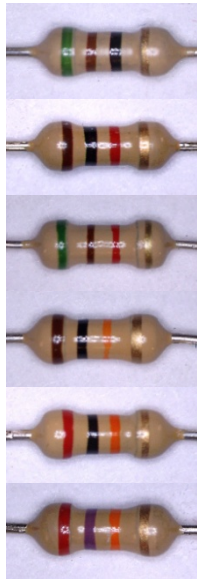

**Qty Description**

- 2 10 K $\Omega$  potentiometer
- 6 0.01  $\mu$ F ceramic capacitor
- 2 0.22  $\mu$ F polyester capacitor
- 5 LM 348 quad op amp
- 1 Trimmer tool

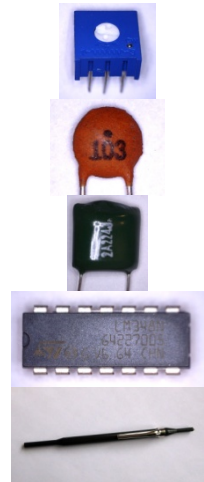

You'll also need breadboards, jumper wires and a laptop or USB stick to capture screenshots.

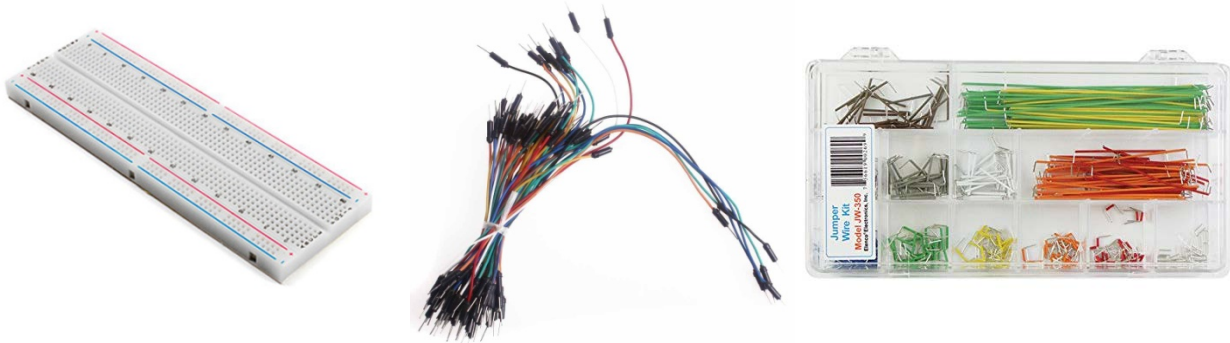

Breadboards come in two common sizes with either 400 or 830 holes. The larger ones, like the one shown here ([at Amazon](#)), are more useful. You'll need them in every lab class you do here and it's helpful not to have to tear down your last circuit just so you can build the next one. So it's probably worth buying a couple of breadboards.

You'll need two types of jumper wires. Flexible jumpers ([at Amazon](#)) are designed for going off-board to the instruments, the power supply, signal generator and oscilloscope. You will also want a kit of pre-cut, pre-formed wires ([at Amazon](#)). These are used for connecting between specific numbers of holes. The resulting wiring is much tidier and easier to debug.

Though I won't be grading it, you will also need a lab notebook with a spiral or other fixed binding to take notes of your experiments with enough information, including any schematics or component values you had to choose, to recreate your work. Your observations in the lab are what they are and they should be written in *ink*, never pencil, each page dated.

You may also find it helpful to simulate the circuits you'll be testing with Multisim as you see in the example on the right so you'll have an idea what to expect when things are wired correctly. It's installed on all the lab machines; a [student license](#) is \$40 and worth the money.

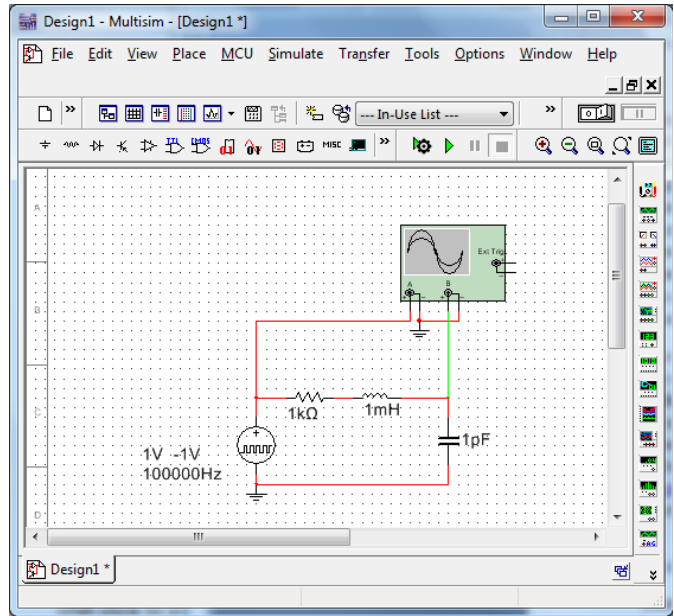

## Teams of 2

Students are expected to work in teams of two. No exceptions. It is up to you to select your partner. My grading will assume equal contributions, meaning you'll both get the same grade. If you find that your partner is not doing his or her share, your options are to try to work it out, swap for a more compatible partner or suck it up. I am not here to settle disputes between lab partners.

Each team should submit *only one* copy of each report but with both names on it. I do not like discovering that I'm grading the same report twice. To turn off the warning from canvas, you may submit an otherwise blank sheet saying only that your partner is submitting.

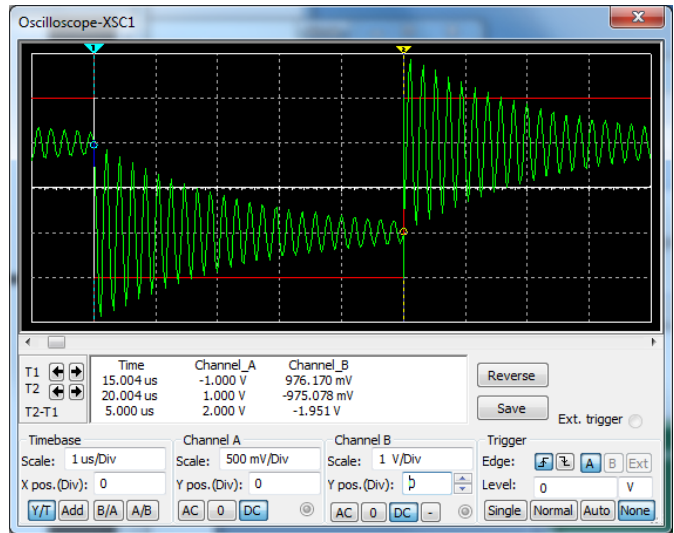

## Reports

Reports may be typed or handwritten neatly in *ink* and submitted in PDF format or on paper. I will not accept cellphone photographs of your work; they're simply too hard to read. If you submit a scan, it must have been made on an actual scanner. There are scanners available for student use in the UWB library in the Information Commons on the first floor. Microsoft Word and other formats can be converted to PDF for free at [PDFOnline.com](#).

Please organize the material in your reports in the *same order* as in the assignments. I'll be reading them onscreen, so it's not helpful to paste things onto the end as appendices or send me hunting for Figure 3 unless it's on the same page. If you're submitting handwritten material, please do not try to squeeze everything onto one page.

I already have a copy of the assignment, so I do not need you to copy-and-paste it into your report. I also do not need title pages with colorful backgrounds, boxes identifying who did what, a list of the standard lab instruments at each bench or any conclusions not called for in the assignment.

## Schematics

I do need you to identify which part of the assignment you're answering and to include a schematic of *each* circuit being discussed. *Each* means every one of them. If you add a wire, I need a new schematic. Please label the inputs and outputs and report measured values for your resistors. If you are asked to choose component values, show your analysis.

(Multisim is also really useful for drawing schematics. To copy a schematic from Multisim into Word as I've done here on the right, start in Multisim by selecting and copying all (Ctrl-A, Ctrl-C). Then in Word, "Paste Special" as a "Picture (Enhanced Metafile)".)

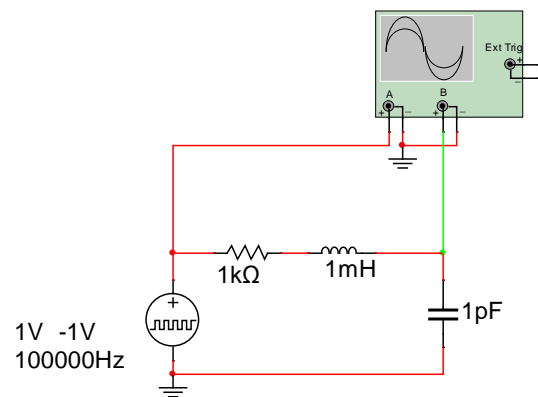

## Measurements

You'll be expected to show that you know how to use the instruments. If you are asked to take measurements, you should report them and do it in sensible units, e.g., 6.32 mV, not .00632 V.

If you're asked to use the multifunction generator, you'll be expected to know how to set the output impedance for the multifunction generator to get the output you intend.

If you're asked to provide an oscilloscope screenshot, it should have input on channel 1, output on channel 2, useful choices for the scales showing around 2 to 5 cycles, relevant onscreen measurements (e.g.,  $V_{pp}$  or frequency) and appropriate positioning of the cursors. Make sure it's large enough that I can easily read it. We're not killing trees, only pixels, so there's no excuse for teeny screenshots I can't read. Screenshots can be saved to a USB stick or by using the Firefox (only!) browser opened to the IP address of the scope.

If you're asked to plot data, your axes must be labeled or the chart is worthless and will be graded accordingly. Scales should be chosen appropriately, e.g., gain in dB is conventionally plotted on a linear scale versus frequency on a logarithmic scale.

If you're asked to make comparisons, the right way to do this isn't to eyeball them (especially if they're on another page) and tell me, "Yup, they look the same to me." The right way is usually a table or chart or similar side-by-side comparison.

If you're asked to explain something, the right answer is usually short.

## Grading

I tend to count up the number of "things" a given lab is asking for, e.g., component value selections, tables of observations, screenshots, questions answered, etc., and assign each a roughly equal value, leaving a little slop for me to deduct points for other reasons, e.g., things out order, hard to read, made me wade through stuff I didn't need, etc. Some points are hard and some are easy but at least they're the same for everyone. The easy way to lose lots of points in a hurry is by forgetting to include something. I almost always give partial credit for an attempt.

I never deduct points simply because your measured results didn't perfectly match the expected. It's experimental data and of course there will be experimental variation. I will deduct if you've made an obvious cockpit error or if you try to "conclude" your data says what you think it was supposed to say if that's not what it actually appears to say.

Realistically, I'm a hard grader on the labs. I am *extremely* picky. I give a lot of 40s and 50s to people who've never seen them before. But bear in mind that each lab is only worth a small percentage of your grade, that I do this to everyone and that it all gets curved. My objective isn't to be difficult but to improve your lab skills. My job is to go over your work to find absolutely everything about your procedure or your analysis that wasn't quite right and tell you, so you'll know how to do it better. If I don't tell you, how would you know?

Overall, I care far more about the quality of your work than about due dates and I tend to be forgiving of late assignments. But if I finish the grading (which usually takes a week, sometimes more) and you still weren't there, it's a zero.

## All the work must be your own

You may certainly compare notes with other teams and of course I understand that you may do research using Google. But absolutely everything you turn in to me must be your own work.

You are expected to contribute equally on every lab. You can break up the tasks on any given lab any way you like. But you may not trade off entire labs, one of you doing all the work on one lab, the other doing all the work on the next. If your name is on the report, you must have contributed to it equally.

Copying answers from another student or off the internet will get a zero, even if you're clear about where you got them. If you omit the attribution, submit work that's not your own or try to deceive me with fabricated results, you will, in addition, *both* be reported for academic misconduct. If there are two names on the report, you're both responsible. I'm

good at spotting misconduct and very good at reporting it. I do not give warnings and I do not accept excuses. I report everything.

## **Disability**

*Access and Accommodations:* Your experience in this class is important to me and to the University of Washington Bothell, where it is our policy and practice to create inclusive and accessible learning environments consistent with federal and state law.

If you experience barriers based on a temporary or permanent disability (including, but not limited to mental health, attention-related, learning, vision, hearing, physical or health impacts), please seek a meeting with [Disability Resources for Students \(DRS\)](#). They'll work with you and me and your other instructors to figure out some reasonable accommodations. The contact person is Rosa Lundborg at 425-352-5307 or email [rlundborg@uwb.edu](mailto:rlundborg@uwb.edu).

If you have already established accommodations with DRS, please tell me what they are so I can be sure to provide them.